

GLASS MELTING BURNERS-FC

- High heat transfer rate to the glass bath
- Reduction of nox emissions
- No maintenance cost
- No coolant necessary
- Easy to install

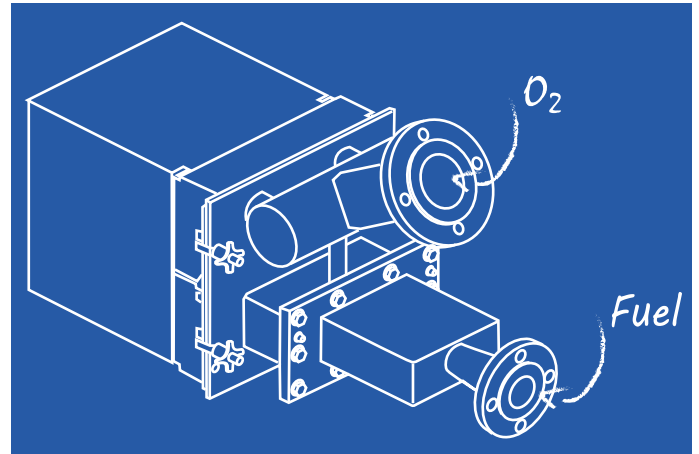

The Concept

GLASS MELTING BURNERS-FC are patented non-water-cooled oxy-fuel burners designed for continuous melting furnaces.

Through this innovative system, fuel and oxygen are introduced into the furnace through a unique configuration of separate injectors, which produces a luminous flat and broad flame.

Applicable Industries

GLASS MELTING BURNERS-FC are used for various glass industries such as:

- Container glass for food and beverages, pharmaceuticals, cosmetics and perfumery.
- TFT-LCD.
- Glass fiber.
- And many others.

Special Features

Oxygen is injected at lower velocity from two injectors located at the top of the burner block. This directs the oxygen flow towards the jets of fuel located in the bottom of the block. Fuel and oxygen are mixed and burned outside the block into the furnace.

The GLASS MELTING BURNERS-FC are composed of:

- A square refractory burner block inserted in the furnace wall.
No additional support of the burner is required.
- A metallic burner body attached to the burner block which ensures the oxygen distribution.
- A fuel injection system.

Both metallic and refractory parts of the burner are cooled by the oxygen flow.

The flame shape, luminosity and stability are controlled thanks to the distribution settings of the oxygen and fuel flow around and into the fuel injectors.

The flame covers the glass bath without local overheating. It also enables a fuel-efficiency increase of more than 5% compared to standard oxy-combustion technology.

This design reduces NO_x emissions by three to five times less than cylindrical flame burners, thanks to lower peak flame temperature.

GLASS MELTING BURNERS-FC are a low pressure drop characteristics burners.

Model Ranges

GLASS MELTING BURNERS-FC are available in three versions and four standards model:

- GLASS MELTING BURNER-FC 200*
- GLASS MELTING BURNER-FC 500*
- GLASS MELTING BURNER-FC 1000*
- GLASS MELTING BURNER-FC 2000*

GLASS MELTING BURNER-FC 500* and **GLASS MELTING BURNER-FC 1000*** can operate either with natural gas or liquid fuel oil. When both liquid fuel oil and natural gas are available, it is possible to switch from one to the other simply by replacing the natural gas lance with the liquid fuel oil lance, without modifying the burner body or the burner block.

GLASS MELTING BURNER-FC 200* and **GLASS MELTING BURNER-FC 2000*** only operate with natural gas.

GLASS MELTING BURNER-FC-VM is available in three standard models:

- GLASS MELTING BURNER-FC-VM 200*
- GLASS MELTING BURNER-FC-VM 500*
- GLASS MELTING BURNER-FC-VM 1000*

Each model is equipped with a pipe-in-pipe type of fuel gas injectors. A valve, positioned upstream the natural gas lance is used to tune the momentum of the gas stream between low momentum and high momentum in the pipes to control the flame shape. They operate with natural gas.

GLASS MELTING BURNER-FC-HEATOX is available in three standard models:

- GLASS MELTING BURNER-FC-HEATOX 500*
- GLASS MELTING BURNER-FC-HEATOX 1000*
- GLASS MELTING BURNER-FC-HEATOX 2000*

GLASS MELTING BURNER-FC-HEATOX can work with preheated reactants (oxygen up to 650°C and fuel gas up to 450°C) but also with cold reactants. Each model has pipe-in-pipe type of injectors in order to achieve the same average fuel-gas jet velocity as **GLASS MELTING BURNERS-FC**, when preheated fuel gas is fed. In the burner a specific actuator automatically manages the flow split between the injectors depending on the operation temperature.

(*) Numbers correspond to the nominal capacity (in kW)

Technical Data

Power (in kW)	Fuel	GLASS MELTING BURNERS-FC	GLASS MELTING BURNERS-FC-VM	GLASS MELTING BURNERS-FC-HEATOX	Block size (mm)
200 (200-300)	Oil	-	-	-	220x220
	NG Propane	O	O	-	
500 (200-750)	Oil	O	-	-	220x220
	NG Propane	O	O	O	
1,000 (400-1,5000)	Oil	O	-	O	275x275
	NG propane	O	O	O	
2,000 (800-3,000)	Oil	-	-	-	330x330
	NG propane	O	-	O	

Related Offer

GLASS MELTING BURNERS-FC are a part of the **Nexelia for Melting solutions**, which are designed and adapted to your needs. There are comprehensive offers that combine the best of our gases, application technologies and expertise support from Air Liquide. With **Nexelia** we work hand in hand defining the results you can expect and we then commit to delivering this performance.

Contact us

Air Liquide Standard Application Equipment - France
 Phone : +33 139 07 62 55
 E-mail : application.equipment@airliquide.com

www.airliquide.com

